



UNIVERSITY OF CAMBRIDGE INTERNATIONAL EXAMINATIONS  
International General Certificate of Secondary Education

CANDIDATE NAME

CENTRE NUMBER

CANDIDATE NUMBER

\* 2 4 3 6 0 5 7 2 3 8 \*

**BIOLOGY**

**0610/33**

Paper 3 Extended

**May/June 2012**

**1 hour 15 minutes**

Candidates answer on the Question Paper.

No Additional Materials are required.

**READ THESE INSTRUCTIONS FIRST**

- Write your Centre number, candidate number and name on all the work you hand in.
- Write in dark blue or black pen.
- You may use a pencil for any diagrams or graphs.
- Do not use staples, paper clips, highlighters, glue or correction fluid.
- DO NOT WRITE IN ANY BARCODES.**

Answer **all** questions.  
 At the end of the examination, fasten all your work securely together.  
 The number of marks is given in brackets [ ] at the end of each question or part question.

For Examiner's Use	
1	
2	
3	
4	
5	
6	
<b>Total</b>	

This document consists of **19** printed pages and **5** blank pages.



- 1 Fig. 1.1 shows a goliath beetle, *Goliathus giganteus*.



Fig. 1.1

- (a) State two features, **visible in Fig. 1.1**, that show that *Goliathus giganteus* is an arthropod.

1 .....

2 ..... [2]

Various arthropods are pests of date palms and cause much damage to this important crop throughout the Middle East.

Fig. 1.2 shows eight species of arthropod that are pests of date palms.

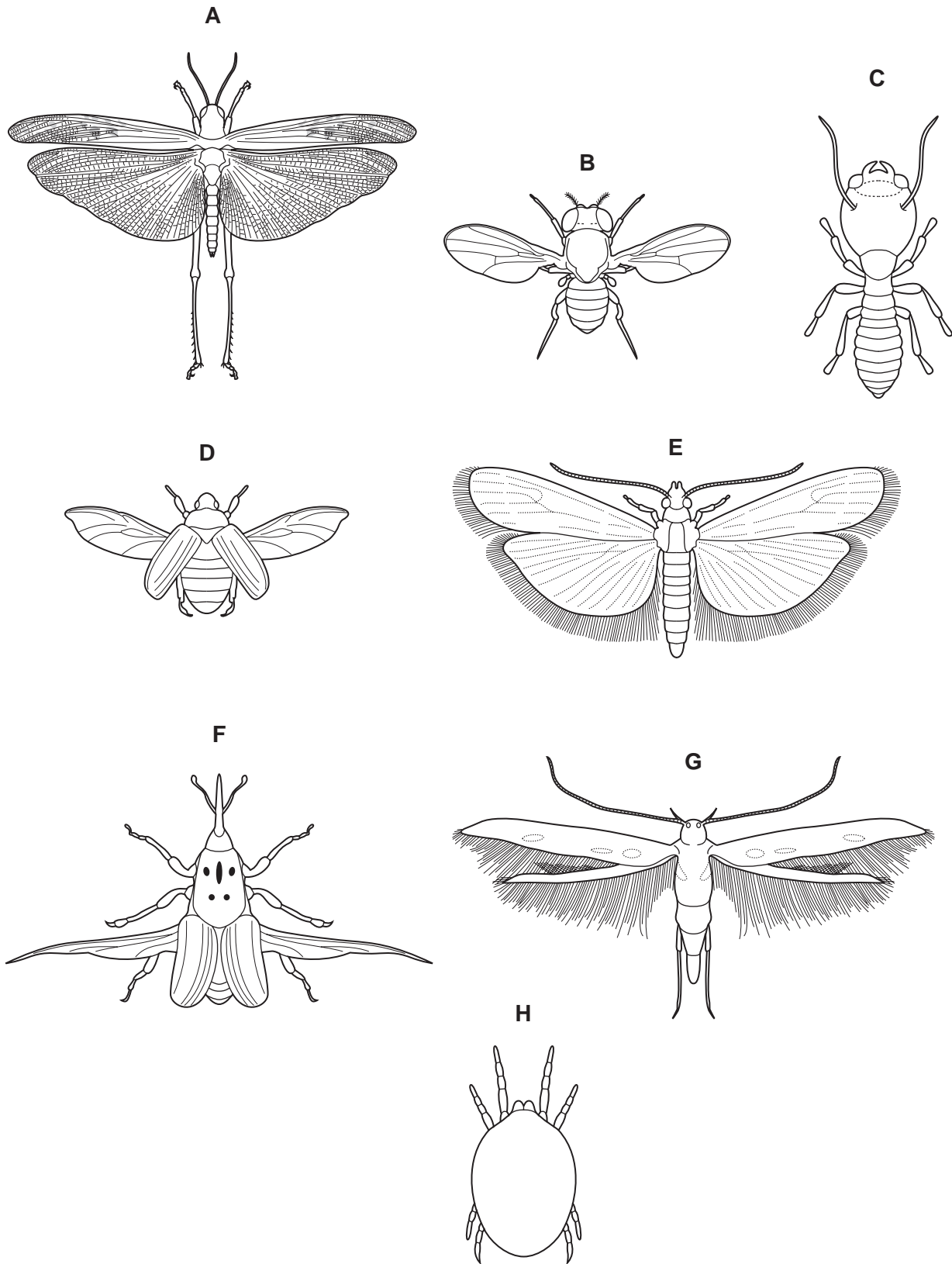

Fig. 1.2

- (b) Use the key to identify each species. Write the letter of each species, **B** to **H**, in the correct box in the key. One, **A**, has been done for you.

**Key**

1 (a)	Wings present	go to 2	
(b)	Wings absent	go to 7	
2 (a)	Back legs adapted for jumping	<i>Schistocerca gregaria</i>	<b>A</b>
(b)	Back legs not adapted for jumping	go to 3	
3 (a)	Two pairs of wings	go to 4	
(b)	One pair of wings	<i>Drosophila melanogaster</i>	.....
4 (a)	Wings with hairs	go to 5	
(b)	Wings with no hairs	go to 6	
5 (a)	Hairs on back wings longer than width of back wing	<i>Epehstia cautella</i>	.....
(b)	Hairs on back wings shorter than width of back wing	<i>Batrachedra amydraula</i>	.....
6 (a)	Thorax with spots	<i>Rhynchophorus ferrugineus</i>	.....
(b)	Thorax with no spots	<i>Oryctes agamemnon</i>	.....
7 (a)	Three pairs of legs	<i>Microcerotermes diversus</i>	.....
(b)	Four pairs of legs	<i>Oligonychus afrasiaticus</i>	.....

[4]





The population density of grasshoppers was recorded for 22 days after spraying. The results are shown in Fig. 1.3.

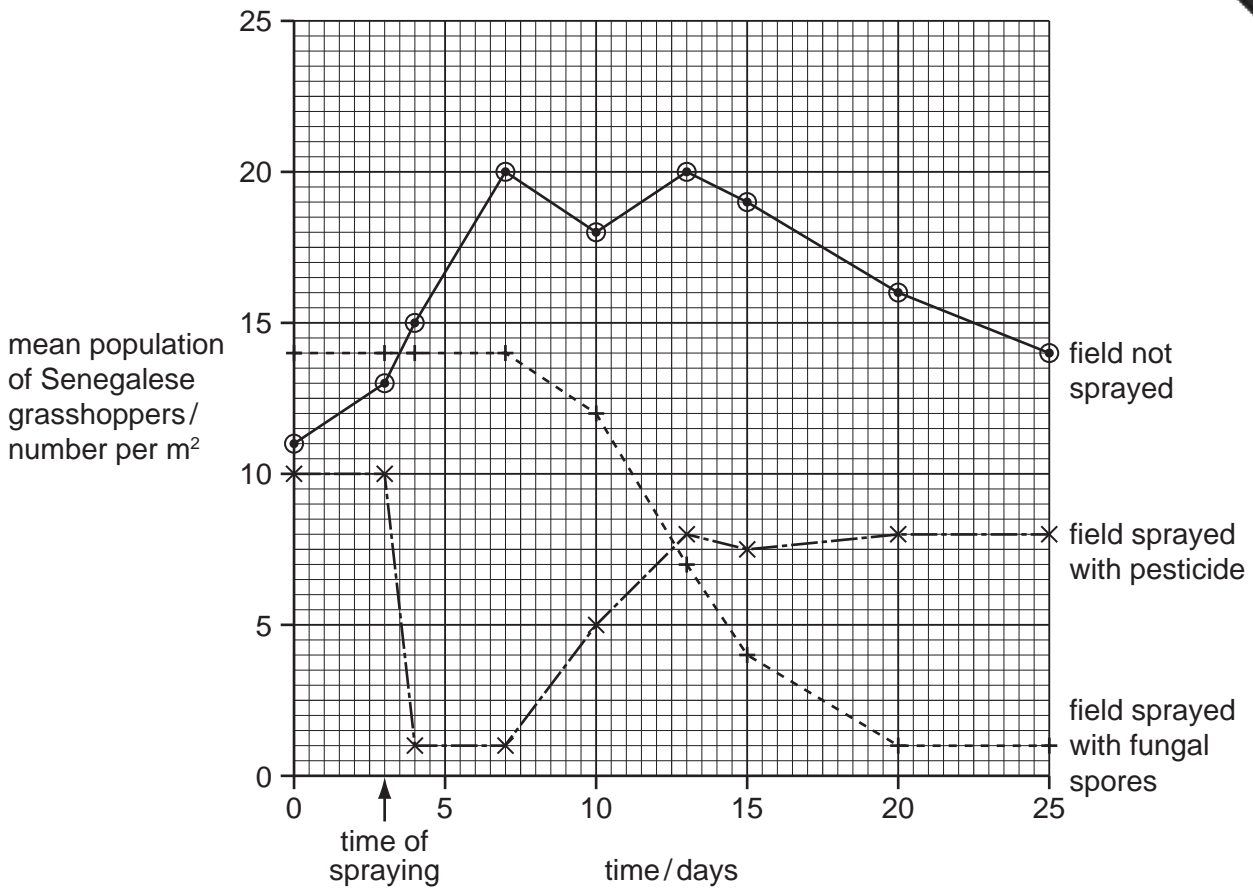

Fig. 1.3

(e) (i) Describe the effects of the two sprays on the populations of grasshoppers. You will gain credit if you use data from Fig. 1.3 to support your answer.

*pesticide* .....

.....  
 .....  
 .....  
 .....

*fungal spores* .....

.....  
 .....  
 .....  
 .....

[5]





2 The light sensitive cells in the eye are known as rods and cones.

Fig. 2.1 shows drawings of a rod cell and a cone cell.

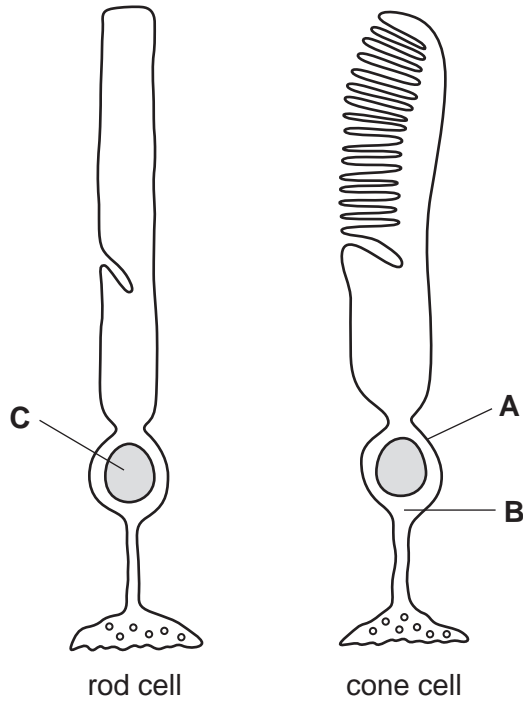

Fig. 2.1

(a) Name the structures labelled A to C.

- A .....
- B .....
- C ..... [3]

(b) (i) Name the tissue in the eye where rods and cones are found.

..... [1]

(ii) Name the parts of this tissue where there are

cones but no rods .....

no cones or rods ..... [2]

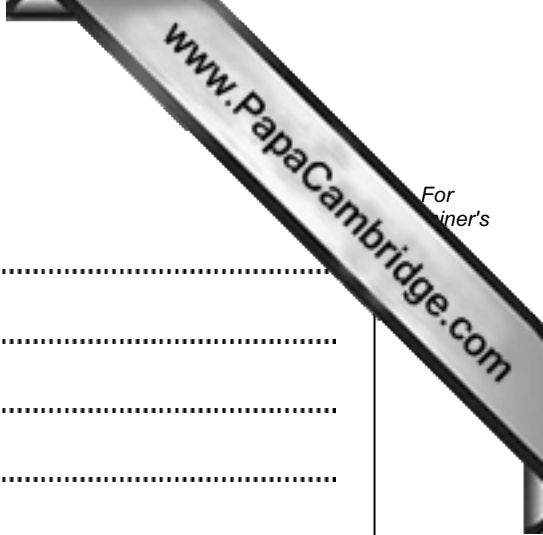

For  
inners

(c) Describe how rods and cones function.

.....

.....

.....

.....

.....

.....

.....

.....

..... [4]

[Total: 10]

3 Many growers of crops in glasshouses use carbon dioxide enrichment to improve yield.

(a) Explain the advantages of carbon dioxide enrichment of glasshouses.

.....

.....

.....

..... [2]

Fig. 3.1 shows the carbon dioxide concentrations inside three glasshouses, **D**, **E** and **F**, on a hot day with bright sunlight.

- Glasshouses **D** and **E** received carbon dioxide enrichment and were ventilated by opening the windows.
- Glasshouse **F** did not receive any extra carbon dioxide and the windows were closed.

The carbon dioxide concentrations in the glasshouses and in the atmosphere were measured. The concentration in the atmosphere was 0.039%.

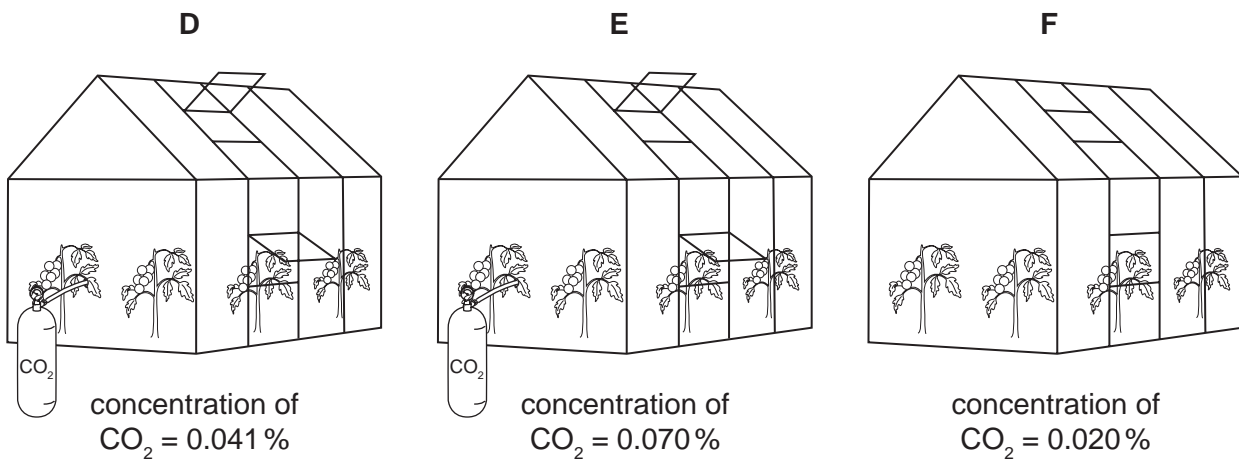
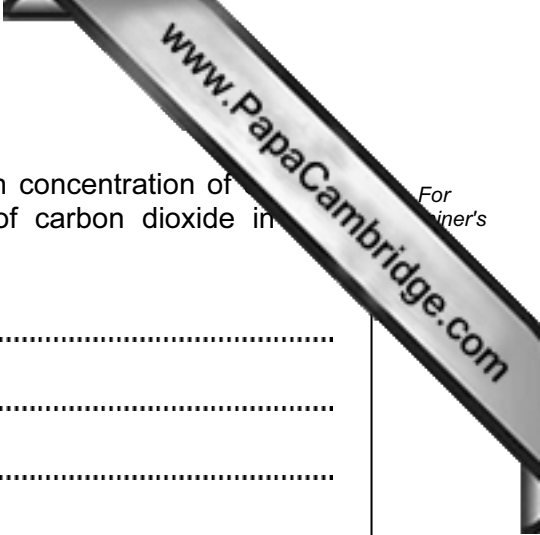

**Fig. 3.1**

The rate of uptake of carbon dioxide by the crop plants was measured in grams of carbon dioxide absorbed per square metre of glasshouse per hour. These results are shown in Table 3.1.

**Table 3.1**

glasshouse	rate of uptake of carbon dioxide by crop plants / g per m <sup>2</sup> per hour
<b>D</b>	2.5
<b>E</b>	5.7
<b>F</b>	1.0



(b) Suggest why it may **not** be cost effective to maintain a high concentration of carbon dioxide in glasshouse **E** compared to the concentration of carbon dioxide in the atmosphere.

.....  
.....  
.....  
.....  
.....  
..... [2]

(c) (i) Concentrations of carbon dioxide in all three glasshouses in Fig. 3.1 increased at night. State why this happened.

..... [1]

(ii) Explain why it is important to ventilate glasshouses by opening the windows.

.....  
.....  
.....  
.....  
.....  
.....  
.....  
..... [4]

[Total: 9]

4 The liver is an organ with a large number of different functions.

Fig. 4.1 shows the liver, its blood supply and some other organs. The blood vessels are labelled P to R.

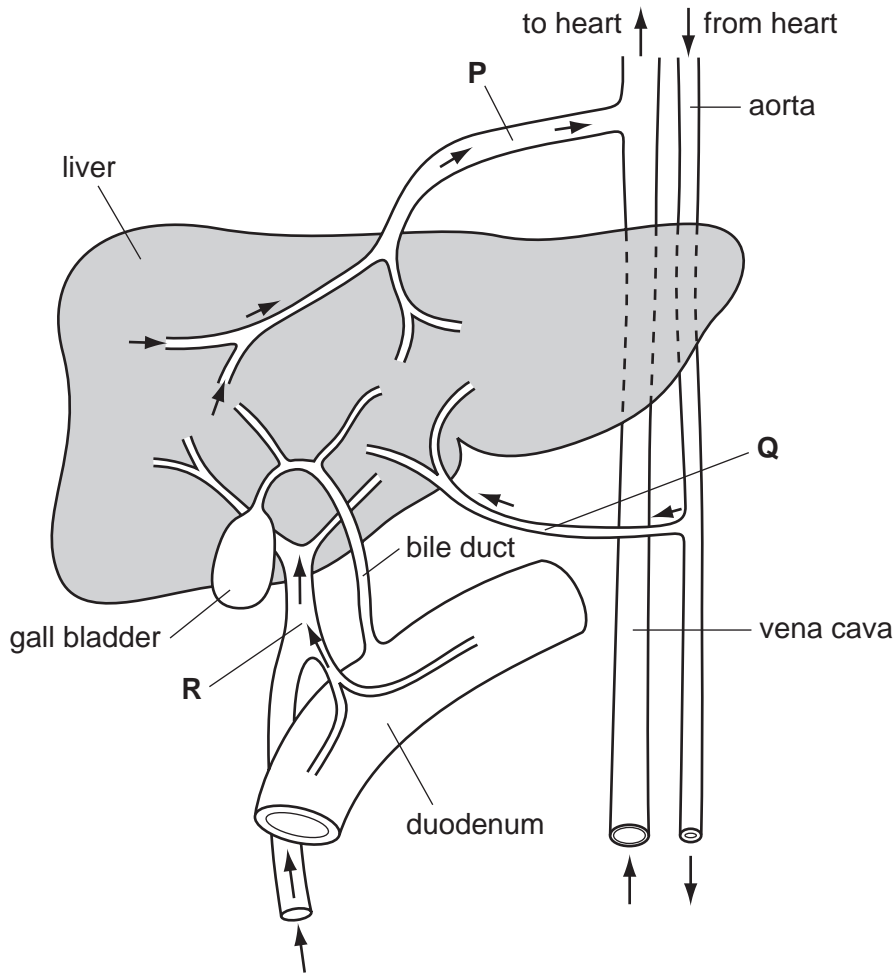

Fig. 4.1

(a) A person eats a meal containing protein and carbohydrate.

Complete Table 4.1 to show the blood vessel that has the **highest** concentration of glucose, oxygen and urea as this meal is absorbed.

Use the letter, P, Q or R to identify each blood vessel.

Table 4.1

substance transported by blood	letter of blood vessel in Fig. 4.1
glucose	.....
oxygen	.....
urea	.....

Write the letters for the blood vessels with the **highest** concentration of each substance in the spaces on Table 4.1. [3]

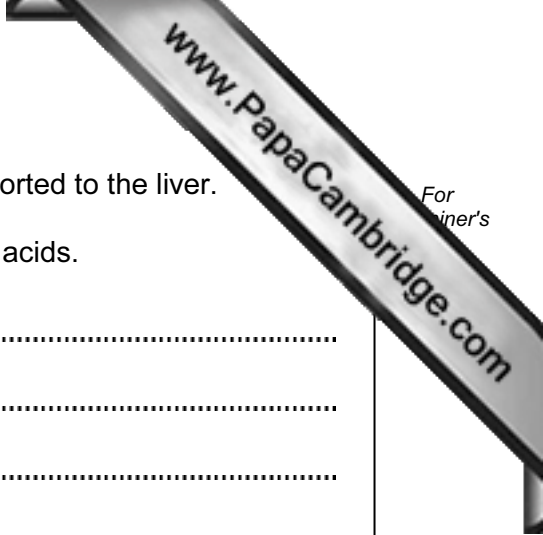

(b) Amino acids are absorbed from the small intestine and transported to the liver.

Describe how the liver is involved in the metabolism of amino acids.

.....  
.....  
.....  
.....  
.....  
..... [3]

(c) Describe the effects on the liver of the following.

(i) insulin released from the pancreas

.....  
.....  
.....  
..... [2]

(ii) adrenaline released from the adrenal glands

.....  
.....  
..... [2]

(iii) excessive long-term consumption of alcohol

.....  
.....  
..... [2]





- 5 The egg cell is the female gamete. Fig. 5.1 shows an ovum at the time of ovulation. The ovum is surrounded by a 'jelly coat' and many follicle cells.

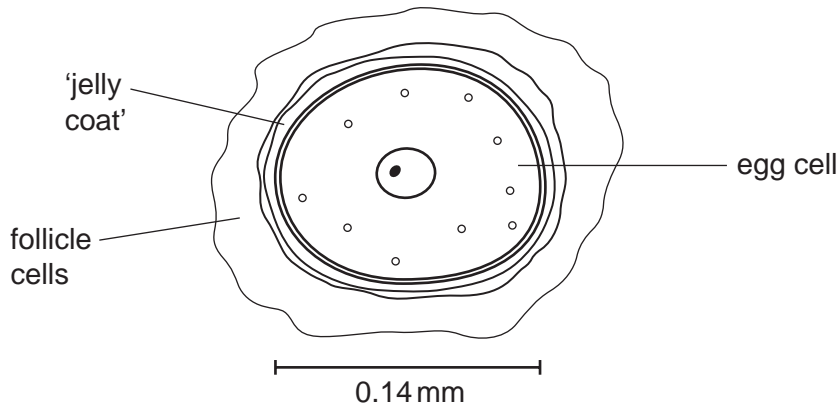

Fig. 5.1

- (a) Calculate the magnification of the egg cell as shown in Fig. 5.1.

Show your working and express your answer to the nearest whole number.

answer = ..... [2]

- (b) State three ways in which the **structure** of an egg cell, as shown in Fig. 5.1, differs from the **structure** of a sperm cell.

- 1 .....
- 2 .....
- 3 ..... [3]

- (c) Meiosis is involved in the production of male and female gametes.

Explain why it is important that meiosis occurs during the production of gametes.

.....

.....

.....

.....

..... [2]

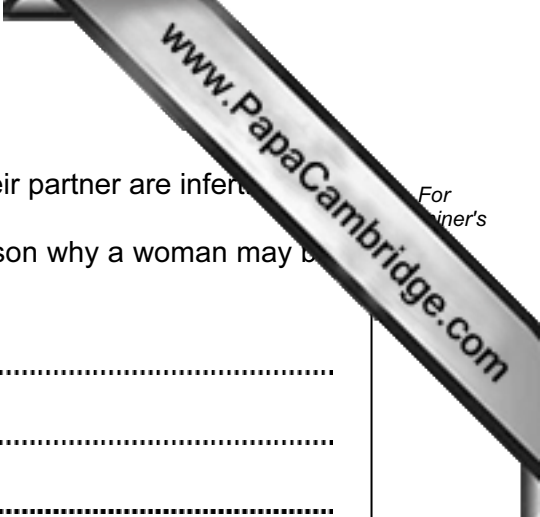

Some women are unable to become pregnant because they or their partner are infertile.

(d) Suggest one reason why a man may be infertile and one reason why a woman may be infertile.

man .....

woman ..... [2]

One way to treat infertility in a woman is to use artificial insemination (AI) using her partner's sperm.

The stages involved in AI are as follows.

1. If the doctor decides that AI is suitable, the woman will be given a course of a fertility drug at an appropriate stage of her menstrual cycle.
2. After two weeks, ultrasound is used to find out when the woman is likely to ovulate.
3. Sperm are collected from the man.
4. The sperm are placed into the uterus of the woman near the time of ovulation.
5. The woman is given an injection of a hormone to encourage the corpus luteum in the ovary to secrete progesterone.

(e) Explain why the sperm must be placed in the uterus near the time of ovulation.

..... [3]

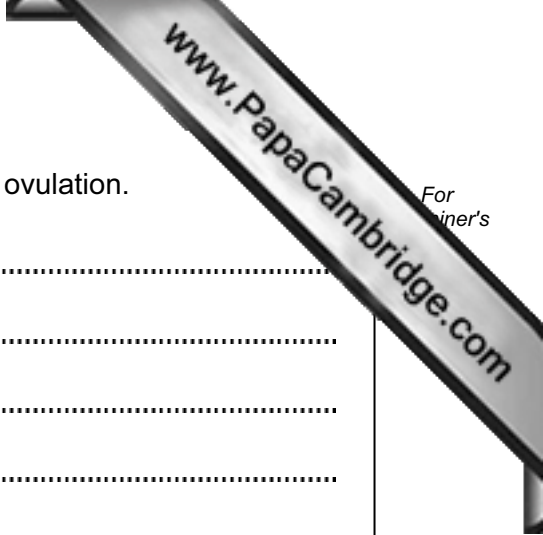

(f) Explain why it is important that progesterone is secreted after ovulation.

.....  
.....  
.....  
.....  
.....  
.....  
..... [3]

(g) The success rate of AI is about 16 %.  
Suggest how the success rate of AI is calculated.

.....  
..... [2]

[Total: 17]

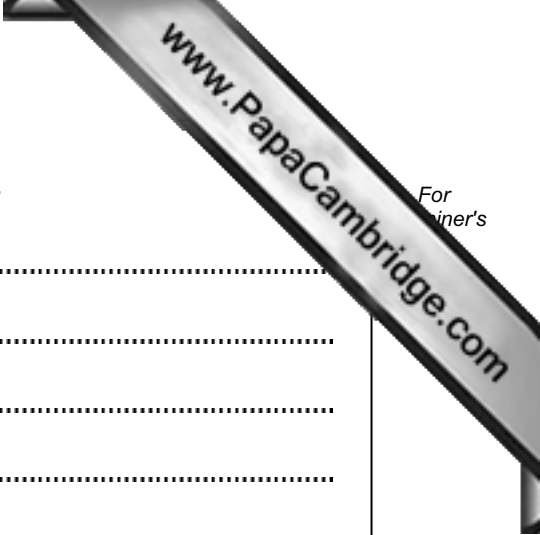

6 (a) Explain why it is important to recycle paper rather than burn it.

.....  
.....  
.....  
.....  
.....  
.....  
..... [3]

When paper is recycled printing ink has to be removed.

Printing ink contains lipid-based compounds. The ink is removed by making the paper into a pulp and mixing it with lipase for several hours.

Scientists in India discovered that the marine bacterium, *Vibrio alginolyticus*, produces lipase. They carried out an investigation to find out whether using *V. alginolyticus* to remove ink from paper pulp was as effective as mixing it with a solution of lipase.

(b) The bacteria were found to be more effective at removing the ink from the paper pulp than using the solution of lipase.

Suggest why.

.....  
.....  
.....  
.....  
.....  
..... [3]

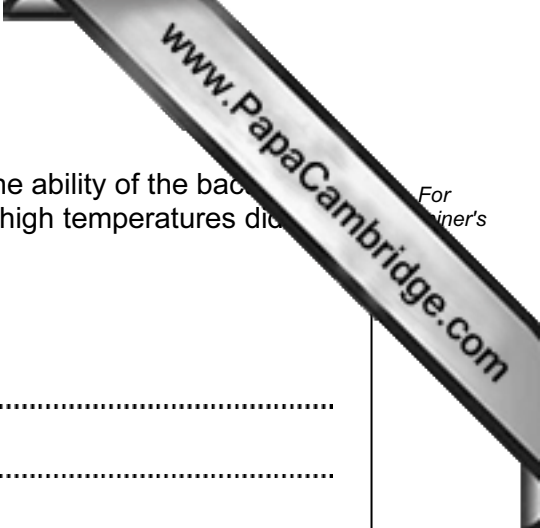

For  
iner's

- (c) The scientists also investigated the effect of temperature on the ability of the bacteria to remove ink from paper pulp. They found that bacteria kept at high temperatures did not remove ink from the paper pulp.

Explain why.

.....

.....

.....

.....

..... [2]

[Total: 8]





---

*Copyright Acknowledgements:*

- Figure 1.1 Photograph      © Maura Fermariella; *Mounted goliath beetle*, Ref: H465/0284; Science Photo Library.  
Figure 1.2                    © *The Biological Control of Grasshoppers and Locusts Programme*; <http://www.lubilosa.org>.  
Question 6                 © Mohandass, C & Chandralata Raghukumar; *Biological deinking of inkjet-printed-paper using Vibrio alginolyticus and its enzymes*; National Institute of Oceanography; Journal of Industrial Microbiology and Biotechnology; 2005.

Permission to reproduce items where third-party owned material protected by copyright is included has been sought and cleared where possible. Every reasonable effort has been made by the publisher (UCLES) to trace copyright holders, but if any items requiring clearance have unwittingly been included, the publisher will be pleased to make amends at the earliest possible opportunity.

University of Cambridge International Examinations is part of the Cambridge Assessment Group. Cambridge Assessment is the brand name of University of